

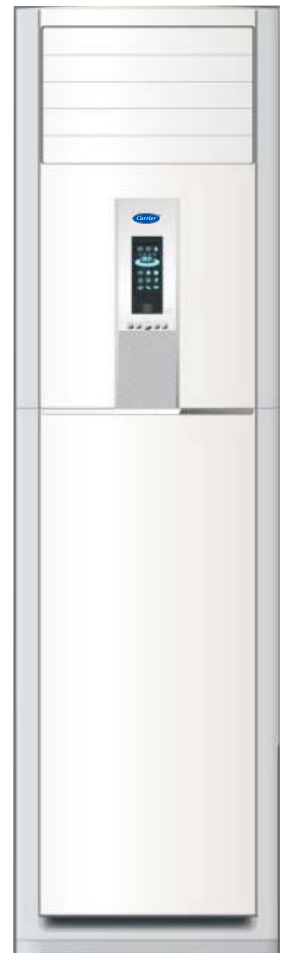

turn to the expertsSM 

USER'S MANUAL

Floor-standing Split Type Air Conditioner



Thank you very much for purchasing our air conditioner,
Before using your air conditioner , please read this manual carefully and keep it for future reference.

CONTENTS

SOCIABLE REMARK

| | |
|----------------------|---|
| Sociable remark..... | 2 |
|----------------------|---|

SAFETY PRECAUTIONS

| | |
|--------------------------|---|
| Warning | 3 |
| Caution | 4 |
| Prior to operation | 5 |

OPERATING INSTRUCTIONS

| | |
|---------------------------------|----|
| Product overview | 6 |
| Unit control panel | 7 |
| Airflow direction control | 10 |
| Operation tips | 11 |

CARE AND MAINTENANCE

| | |
|--|----|
| Cleaning the indoor unit | 12 |
| Cleaning the air outlet | 12 |
| Cleaning the air inlet grille and air filter | 13 |

TROUBLESHOOTING TIPS

| | |
|----------------------------|----|
| Troubleshooting tips | 14 |
|----------------------------|----|

CAUTION

- Contact an authorised service technician for repair or maintenance of this unit.
- Contact the installer for installation of this unit.
- The air conditioner is not intended for use by young children or invalids without supervision.
- Young children should be supervised to ensure that they do not play with the air conditioner.
- If the power cord is to be replaced, replacement work shall be performed by authorised personnel only.
- Installation work must be performed in accordance with the national wiring standards by authorised personnel only.

The following contents apply only to the countries of Europe.

DISPOSAL: Do not dispose this product as unsorted municipal waste. Collection of such waste separately for special treatment is necessary.

It is prohibited to dispose of this appliance in domestic household waste.

For disposal, there are several possibilities:



- A) The municipality has established collection systems, where electronic waste can be disposed of at least free of charge to the user.
- B) When buying a new product, the retailer will take back the old product at least free of charge.
- C) The manufacture will take back the old appliance for disposal at least free of charge to the user.
- D) As old products contain valuable resources, they can be sold to scrap metal dealers.

Wild disposal of waste in forests and landscapes endangers your health when hazardous substances leak into the ground-water and find their way into the food chain.





SAFETY PRECAUTIONS

To prevent injury to the user or other people and property damage, the following instructions must be followed. Incorrect operation due to ignoring of instructions may cause harm or damage. The seriousness is classified by the following indications.

| | |
|--|--|
|  WARNING | This symbol indicates the possibility of causing death or serious injury. |
|  CAUTION | This symbol indicates the possibility of causing injury or damage to property. |

■ Meanings of symbols used in this manual are as shown below.

| | |
|---|------------------------|
|  | Never do this. |
|  | Always do this. |

WARNING

| | | |
|--|--|---|
| ① Connect with the power properly. | ⊘ Do not operate or stop the unit by switching on or off the power. | ⊘ Do not damage or use an unspecified power cord. |
| ● Otherwise, it may cause electric shock or fire due to excess heat generation. | ● It may cause electric shock or fire due to heat generation. | ● It may cause electric shock or fire. |
| ① Do not modify power cord length or share the outlet with other appliances | ⊘ Do not operate with wet hands or in damp environment. | ⊘ Do not direct airflow at room occupants only. |
| ● It may cause electric shock or fire due to heat generation. | ● It may cause electric shock. | ● This could damage your health. |
| ① Always ensure effective earthing. | ⊘ Do not allow water to run into electric parts. | ① Always install circuit breaker and a dedicated power circuit. |
| ● No earthing may cause electric shock. | ● It may cause failure of machine or electric shock. | ● No installation may cause fire and electric shock. |
| ① Disconnect the power if strange sounds, smell, or smoke comes from it. | ⊘ Do not drink water drained from air conditioner. | ⊘ Do not open the unit during operation. |
| ● It may cause fire and electric shock. | ● It contains contaminants and could make you sick. | ● It may cause electric shock. |
| ① Use the correctly rated breaker or fuse. | ⊘ Do not use the power cord close to heating appliances | ⊘ Do not use the power cord near flammable gas or combustibles, such as gasoline, benzene, thinner, etc. |
| ● There is risk of fire or electric shock. | ● It may cause fire and electric shock. | ● It may cause an explosion or fire. |
| ① Ventilate room before operating air conditioner if there is a gas leakage from another appliance. | ⊘ Do not disassemble or modify unit. | |
| ● It may cause explosion, fire and, burns. | ● It may cause failure and electric shock. | |

⚠ CAUTION

Ⓞ When the air filter is to be removed, do not touch the metal parts of the unit.

- It may cause an injury.

Ⓞ When the unit is to be cleaned, switch off, and turn off the circuit breaker.

- Do not clean unit when power is on as it may cause fire and electric shock, it may cause an injury.

Ⓞ Stop operation and close the window in storm or hurricane.

- Operation with windows opened may cause wetting of indoor and soaking of household furniture.

Ⓞ Do not use strong detergent such as wax or thinner. Use a soft cloth for cleaning.

- Appearance may be deteriorated due to change of product color or scratching of its surface.

Ⓞ Do not place heavy object on the power cord and take care of it so that the cord is not compressed.

- Do not operate your air conditioner in a wet room such as a bathroom or laundry room.

Ⓞ This appliance can be used by children aged from 8 years and above and persons with reduced physical, sensory or mental capabilities or lack of experience and knowledge if they have been given supervision or instruction concerning use of the appliance in a safe way and understand the hazards involved. Children shall not play with the appliance. Cleaning and user maintenance shall not be made by children without supervision.

Ⓞ Do not clean the air conditioner with water.

- Water may enter the unit and degrade the insulation. It may cause an electric shock.

Ⓞ Do not put a pet or house plant where it will be exposed to direct air flow.

- This could injure the pet or plant.

Ⓞ Do not place obstacles around air-inlets or inside of air-outlet.

- It may cause failure of appliance or accident.

Ⓞ Ensure that the installation bracket of the outdoor appliance is not damaged due to prolonged exposure.

- If bracket is damaged, there is concern of damage due to falling of unit.

Ⓞ Use caution when unpacking and installing. Sharp edges could cause injury.

- Children should be supervised to ensure that they do not play with the appliance.

Ⓞ This appliance is not intended for use by persons (including children) with reduced physical, sensory or mental capabilities, or lack of experience and knowledge, unless they have been given supervision or instruction concerning use of the appliance by a person responsible for their safety.

Ⓞ Ventilate the room well when used together with a stove, etc.

- An oxygen shortage may occur.

Ⓞ Do not use for special purposes.

- Do not use this air conditioner to preserve precision devices, food, pets, plants, and art objects. It may cause deterioration of quality, etc.

Ⓞ Turn off the main power switch when not using the unit for a long time.

- It may cause failure of product or fire.

Ⓞ Always insert the filters securely. Clean filter once every two weeks.

- Operation without filters may cause failure.

Ⓞ If water enters the unit, turn the unit off and disconnect the power, contact a qualified service technician.

- There is danger of fire or electric shock.

Ⓞ If the supply cord is damaged, it must be replaced by the manufacturer, its service agent or similarly qualified persons in order to avoid a hazard.

Prior to operation

1. Contact an installation specialist for installation.
2. Make sure the unit is grounded efficiently.
3. Do not use a damaged or non-standard power cord.
4. Do not share the same outlet with other appliances.
5. Do not use an extension cord.
6. Do not start/stop operation by shutting off the power supply.

Usage

1. Exposure to direct airflow for an extended period of time could be hazardous to your health. Do not expose occupants, pets, or plants to direct airflow for extended periods of time.
2. Due to the possibility of oxygen deficiency, ventilate the room when used together with stoves or other heating devices.
3. Do not use this air conditioner for non-specified special purposes (e.g. Preserving precision devices, food, pets, plants, and art objects). Usage in such a manner could harm such property.

Cleaning and maintenance

1. Do not touch the metal parts of the unit when removing the filter. Injuries can occur when handling sharp metal edges.
2. Do not use water to clean inside the air conditioner. Exposure to water can destroy the insulation, leading to possible electric shock.
3. When cleaning the unit, first make sure that the power and circuit breaker are turned off.

service

For repair and maintenance, contact your authorised service dealer.

Operating temperature

| Mode Temperature | Cooling operation | Heating operation | Drying operation |
|--|--|----------------------|-----------------------|
| Room temperature | 17°C~32°C/62°F~90°F | 0°C ~30°C/32°F~86°F | 17°C~32°C/62°F~90°F |
| Outdoor temperature | 0°C~50 °C/32°F~122°F | -15°C~ 24°C/5°F~76°F | 0 °C~50 °C/32°F~122°F |
| | (-15°C~50°C/5°F~122°F: For the models with low temperature cooling system) | | |
| <p>CAUTION:</p> <ol style="list-style-type: none"> 1. If air conditioner is used outside of the above conditions, certain safety protection features may come into operation and cause the unit to function abnormally. 2. Room relative humidity less than 80%. If the air conditioner operates in excess of this figure, the surface of the air conditioner may attract condensation. Please set the vertical air flow louver to its maximum angle (vertically to the floor), and set HIGH fan mode. 3. Optimum performance will be achieved within these operating temperature. | | | |

Product Overview

Indoor unit

- ① Air outlet
- ② Operation panel
- ③ Horizontal airflow control louver
- ④ Vertical airflow control louver
- ⑤ Remote controller holder(on some models)
- ⑥ Air inlet(2 sides)

Outdoor unit

- ⑦ Drain pipe, vent pipe
- ⑧ Connection cable
- ⑨ Connection pipe
- ⑩ Refrigerant pipe port
- ⑪ Air outlet

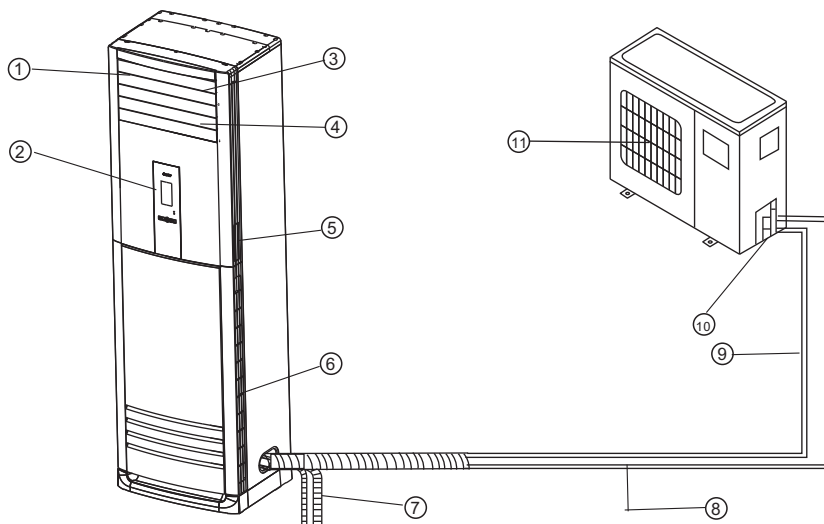

NOTE

All the pictures in this manual are for explanation purpose only. They may be slightly different from the air conditioner you purchased(depend on model). The actual shape shall prevail.

NOTE: This manual does not include Remote Controller Operations, see the <<Remote Controller Instruction>> packed with the unit for details.

Unit Control Panel

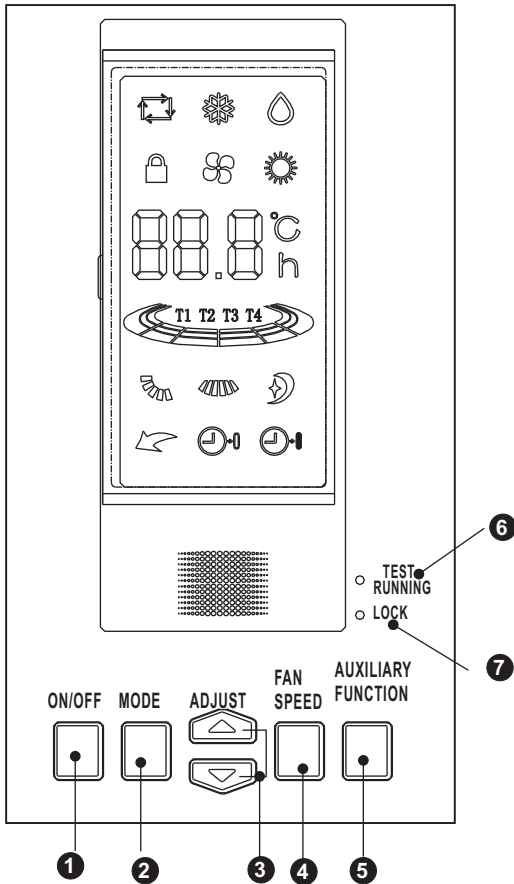

Indicators

- Auto operation display
- Cooling operation display
- Dry operation display
- Heating operation display
- Fan operation display
- Up and down airflow display
- Left and right airflow display
- Sleep operation display
- Turbo operation display
- On timer operation display
- Off timer operation display
- Lock operation display
- Room Temp/Set Temp /Set Timer display
- T1 T2 T3 T4 Testing information display
- Fan speed display

Operation buttons

- 1 ON/OFF button:** Operation starts when this button is pressed and stops when you press the button again.
- 2 MODE button:** Press this button to select the appropriate operating mode. Each time the button is pressed, the operation mode is shifted in the direction of the arrow:

Mode indicators illuminate under the different mode settings.

- Auto:** Automatically choose the operation mode by sensing the difference between the actual ambient room temperature and the set temperature on the remote controller. The fan speed is automatically controlled.
- Cool:** Enables you to enjoy the cooling effect at your preferred setting temperature (Temperature range: 17°C~30°C).
- Dry:** Enables you to set the desired temperature at low fan speed which provides you with the dehumidifying surroundings (Temperature range: 17°C~30°C). In Dry mode, you can not select Fan speed and Sleep mode.
- Heat:** Permits heating operation (For cooling & heating models only) (Temperature setting range: 17°C~30°C)
- Fan only:** Permits fan operation without cooling or heating. In this case, however, the setting temperature is not displayed and you can not adjust the set temperature.

3 ADJUST button function:

1. **Temperature adjust:** Press the "▲" and "▼" to adjust the temperature in a range of 17°C~30°C.
2. **Timer adjust:** Adjust the timer on/off time under the Timer setting mode(0~24hs).
3. **Auxiliary function selection:** Select the desired auxiliary function by pressing "▲" and "▼" button.
4. Under the Test Running mode, press "▲" "▼" to check information about T1, T2, (T3), (T4), P0, P1, P8. If no protection function occurs, the code is shifted.
5. Under malfunction condition: Press the "▲" and "▼" to check the malfunction code E1, E2, E3, E4, E7, E8, or Ed (details refer to TROUBLESHOOT TIPS on page 14). It displays "dF" while defrosting.
6. Under any of the above circumstance, if keep pressing the "▲" and "▼" without releasing, the setting changes 4 times per second.

4 FAN SPEED button: This button is used to select the desired fan speed. Each time you push the button, a fan speed is shifted in the direction of the arrow:



NOTE: You can not select a fan speed under AUTO and DRY mode. The fan motor operates at pre-set AUTO speed under AUTO mode and at LOW speed under DRY mode.

Fan speed displays:

The display is separated into 3 zones. When setting the speed, the corresponding zone will illuminate.

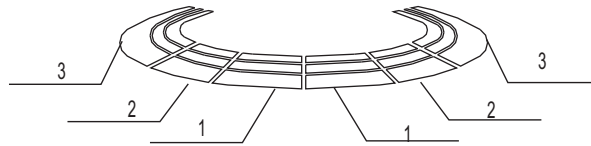

Select LOW fan speed and the first zone will illuminate;

Select AUTO fan speed and zones 1~2 will illuminate;

Select HIGH fan speed and zones 1~3 will illuminate.

Once selected, after 2 seconds the zones will illuminate gradually based on the speed selected.

For example, HIGH fan speed will show the display illuminating quickly from zone to zone.

Note: when the indoor fan is stopped, nothing will display.

5 AUXILIARY FUNCTION button: Use this button to select or cancel the auxiliary feature.

Press this button, then press the ADJUST "▲" and "▼" button to select the desired feature. Each time the button is pressed, the mode is shifted in the direction of the arrow:

If press "▲" button:

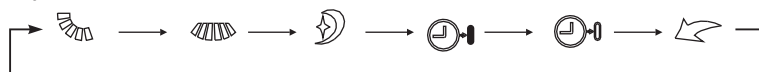

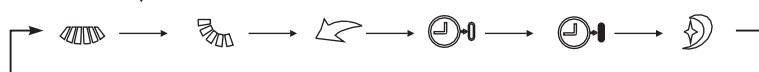

If press "▼" button:



Once the desired feature is established, press the AUXILIARTY FUNCTION button again to register.

NOTE: The above illustration is for explanation purpose only. The features are different depending on models.

Relative indicator lights up under the different mode settings:

-  **Up/Down airflow:** Enables you to set the desired vertical airflow direction.
-  **Left/Right airflow:** Enables you to set the desired horizontal airflow direction.
-  **Sleep operation:** Choose this feature to go into the energy-saving operation. It is only available on Cool, Heat or Auto mode. Under Sleep mode, the air conditioner will automatically increase (cooling) or decrease (heating) 1°C per hour. The set temperature will be stable 2 hours later. The fan speed is forced AUTO.

 **Turbo operation:** When select this function in cooling mode, the fan motor will operate at super high fan speed and the set temperature will reach in the shortest time. After half an hour, the fan speed will revert back to the previous set fan speed. The fan speed can be adjusted under Turbo operation. When select this function in heating mode (Applicable to the unit adopts PTC heater only), the PTC heater is activated and brings faster and stronger heating.

NOTE: This function is not available under sleep operation.

 **Timer ON operation:** Use the ON timer to turn on the air conditioner at the desired time (between 0~24hrs). After selecting the Timer ON feature, press the "▲" and "▼" button to select the desired time, each press will increase/decrease the Auto-timed setting in 30 minute increments. Once the desired time is established, press the AUXILIARY FUNCTION button to register the Auto Timer-ON program.

 **Timer OFF operation:** Use the OFF timer to turn off the air conditioner at the desired time (between 0~24hrs). After selecting the Timer OFF feature, press the "▲" and "▼" button to select the desired time, each press will increase/decrease the Auto-timed setting in 30 minute increments. Once the desired time is established, press the AUXILIARY FUNCTION button to register the Auto Timer-OFF program.

NOTE: To cancel the timer settings, press the AUXILIARY FUNCTION button, then use the "▲" and "▼" buttons to select ON/OFF timer, press the AUXILIARY FUNCTION button again to cancel.

6 TEST RUNNING button: This button is specially designed for maintenance technicians. Press this button to perform test running operation, press it again to stop the operation. The test running operation will last 30 minutes regardless of the setting temperature. In this case, press the ADJUST button to check the protective code of T1, T2, T3 and T4 (For Cooling & Heating models only).

7 LOCK button: When you press the **LOCK** button the first time, all the current settings are locked in but the remote controller operation is available. And the LOCK indicator () illuminates. Push it again to cancel the **LOCK** mode.

Airflow Direction Control

Horizontal Airflow Direction(AUTO)

The Left/Right(Horizontal Airflow) can be adjusted by using the remote control or unit control. Press the "AUXILIARY FUNCTION" button on the unit control panel, then press the ADJUST "▲" and "▼" button to select the "  " feature and the louvers will swing left and right. Repeat the above procedures to stop the swing operation.

Vertical Airflow Direction(AUTO)

The Up/Down(Vertical Airflow) can be adjusted by using the remote control or unit control. Press the "AUXILIARY FUNCTION" button on the unit control panel, then press the ADJUST "▲" and "▼" button to select the "  " feature and the horizontal louvers will swing up and down. Repeat the above procedures to stop the swing operation. When turn off the unit, the horizontal louvers will automatically closed to prevent dust.

WARNING: Manually moving the horizontal and vertical airflow direction louvers could damage the air conditioner.

Note:

- The starting angle of the horizontal louver should not be too small, otherwise the narrow air outlet will affect cooling or heating efficiency.
- Do not set the starting angle of the louvers too small during cooling or drying operation. Otherwise, condensation may occur on the surface of the horizontal louver and cause dew dripping.
- During the operation, if the louvers can not swing normally, shut off the unit and unplug for several minutes, then plug it again and restart the operation.
- The horizontal louver may slightly vibrate during the operation. This is normal.

Operation Tips

The following events may occur during normal operation.

1. Protection of the air conditioner.

Compressor protection

- The compressor can't restart for 3 minutes after it stops.

Anti-cold air (Cooling and heating models only)

- The unit is designed not to blow cold air on HEAT mode, when the indoor heat exchanger is in one of the following three situations and the set temperature has not been reached.

- A) When heating has just starting.
- B) Defrosting.
- C) Low temperature heating.

- The indoor or outdoor fan stop running when defrosting (Cooling and heating models only).

Defrosting (Cooling and heating models only)

- Frost may be generated on the outdoor unit during heat cycle when outdoor temperature is low and humidity is high resulting in lower heating efficiency of the air conditioner.
- During this condition air conditioner will stop heating operation and start defrosting automatically.
- The time to defrost may vary from 4 to 10 minutes according to the outdoor temperature and the amount of frost buildup on the outdoor unit.

2. A white mist coming out from the indoor unit

- A white mist may generate due to a large temperature difference between air inlet and air outlet on COOL mode in an indoor environment that has a high relative humidity.
- A white mist may generate due to moisture generated from defrosting process when the air conditioner restarts in HEAT mode operation after defrosting.

3. Low noise of the air conditioner

- You may hear a low hissing sound when the compressor is running or has just stopped running. This sound is the sound of the refrigerant flowing or coming to a stop.
- You can also hear a low "squeak" sound when the compressor is running or has just stopped running. This is caused by heat expansion and cold contraction of the plastic parts in the unit when the temperature is changing.
- A noise may be heard due to louver restoring to its original position when power is first turned on.

4. Dust is blown out from the indoor unit.

This is a normal condition when the air conditioner has not been used for a long time or during first use of the unit.

5. A peculiar smell comes out from the indoor unit.

This is caused by the indoor unit giving off smells permeated from building material, from furniture, or smoke.

6. The air conditioner turns to Fan Mode from COOL or HEAT (For cooling and heating models only) Mode.

When indoor temperature reaches the temperature setting on air conditioner, the compressor will stop automatically, and the air conditioner turns to Health mode. The compressor will start again when the indoor temperature rises on COOL mode or falls on HEAT mode (For cooling and heating models only) to the set point.

7. Dripping water may generate on the surface of the indoor unit when cooling in a high relatively humidity (relative humidity higher than 80%). Adjust the horizontal louver to the maximum air outlet position and select HIGH fan speed.

8. Heating mode (For cooling and heating models only)

The air conditioner draws in heat from the outdoor unit and releases it via the indoor unit during heating operation. When the outdoor temperature falls, heat drawn in by the air conditioner decreases accordingly. At the same time, heat loading of the air conditioner increases due to larger difference between indoor and outdoor temperature. If a comfortable temperature can't be achieved by the air conditioner, we suggest you use a supplementary heating device.

9. Auto-restart function

Power failure during operation will stop the unit completely.

For the unit without Auto-restart feature, when the power restores, the OPERATION indicator on the indoor unit starts flashing. To restart the operation, push the ON/OFF button on the remote controller. For the unit with Auto-restart feature, when the power restores, the unit restarts automatically with all the previous settings preserved by the memory function.

10. Lightning or a car wireless telephone operating nearby may cause the unit to malfunction. Disconnect the unit with power and then re-connect the unit with power again. Push the ON/OFF button on the remote controller to restart operation.

11. Vent function

This machine is special designed with Vent function, it is automatically initiated by the fan motor. The air conditioner have a vent pipe in the indoor unit, when the fan motor is operational, the indoor polluted air flow out of the room via the vent pipe.

Maintenance and Cleaning

CAUTION: Before performing any maintenance, turn off the main power to the system.

Cleaning the indoor unit:

Note: Turn the system off before cleaning. Supply power must be disconnected before cleaning the indoor unit.

1. Use a dry cloth to wipe the indoor unit and remote controller.
2. A cloth dampened with cold water may be used on the indoor unit if it is very dirty.
3. Do not splash water on unit. This may cause damage to the inner parts or an electric shock.

CAUTION:

1. Do not use a chemical-treated duster for wiping or leave such material on the unit for long.
2. Do not use benzine, thinner, polishing powder, or similar solvents for cleaning.
These may cause the plastic surface to crack or deform.

Cleaning the air outlet:

After using for a period, the air outlet and louvers will become dirty. It is recommended to dip a soft cloth into warm water or a mild kitchen cleanser, ring it out, then wipe any soiling from the unit. After, wipe with a dry cloth.

Cleaning the Air inlet grille and Air Filter:

If the air filter becomes clogged, the performance will decrease and electricity will be wasted. The air filter should be checked and cleaned about once every 2 weeks to maintain optimal performance of the air conditioner.

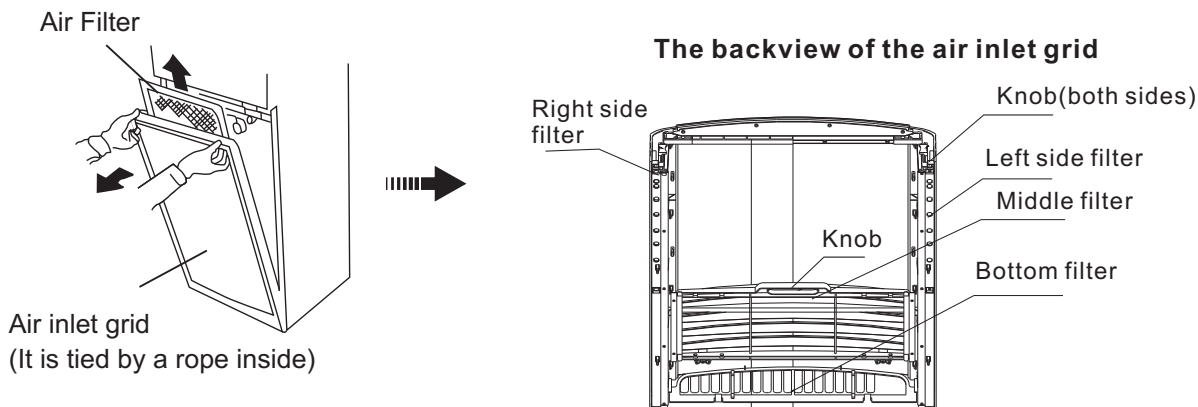

Note:

The Anti-formol filter fixed on the Air filter does not need replacement, just wash it with cold water and dry it in the shadow.

1. There are four pieces of air filter attached with the air inlet grid, located at both sides, middle of grid and at the bottom of the grid (see figure above).
2. Hold both upper sides of the grid and pull it up, let it slant downwards until the rope become straight.
3. Take hold of the knob of the air filter and pull it upward.
4. The air inlet grid should be removed first before take out the middle and bottom filters. Use the screwdriver to loosen the screw fasten the rope, then remove the air inlet grid.
3. The air inlet grid can be wiped with water or a cloth dipped water. Wash it with water and dry it in a cool place.
4. Use a vacuum cleaner to remove the dust or wash the air filter with water, and dry it in the shadow.
5. Installation process of the air filter and air inlet grid is the reverse of the removal process.

CAUTION:

Make sure nothing has been forgotten or fallen into the fan before installing the air inlet grille. Restart the unit after the air inlet grid is correctly installed and the loop is fastened.

TROUBLESHOOTING TIPS

Before long time idleness

1. Clean the indoor unit and air filter.
2. Dry the inner parts by keeping the fan running for half a day.
3. Turn off the unit and switch off the power switch, remove the batteries from the remote control.
4. Periodically check and clean the inner parts of the outdoor unit. Our local dealer will help you handle this if you contact us.

After long time idleness

Before restarting, please check if the air inlet and air outlet of the indoor and outdoor units are blocked up. Clean it so.

Aftersales

If the air conditioner operate abnormally, turn off the unit and switch off the power supply, and contact the local dealer or service centre.

Troubleshooting tips

Before calling for service, please review the following list of common problems and solutions.

| Problem | Possible Cause | Solutions |
|--|--|--|
| Air conditioner does not operate at all | Power failure | Wait for power restoring |
| | The power supply is disconnected. | Switch on the main power switch |
| | The power fuse is blown. | Change the fuse |
| | The timer is set. | Wait or cancel timer setting |
| | The batteries of the remote control are exhausted | Change the batteries. |
| Air conditioner does not cool or heat well | The temperature setting is too high or too low. | Set a more comfortable temperature. |
| | The air filter is clogged with dust | Clean the filter |
| | The air inlet or outlet of the outdoor unit is blocked | Clear up the block |
| | Doors or windows are open | Close the doors or windows |
| Air conditioner does not cool or heat at all | The air inlet or outlet of the outdoor unit is blocked | Clear up the block first, then begin to operate. |
| | Three-minute protection feature | Wait for a while |
| | Unappropriated temperature setting | Set the temperature properly |

If you still cannot solve the problem after trying the above, pull out the power plug and call the dealer.

TROUBLESHOOTING TIPS

If you still cannot solve the problem after trying the above, pull out the power plug and call the dealer.

The following displays indicate an error or problem:

| Number | Display code | Problems | What to do |
|--|--------------|--|--|
| 1 | E1 | IDU & ODU communication malfunction | Contact service people |
| 2 | E2, E3,E4 | Temperature Sensor is off or short-circuit. | Contact service people |
| 3 | E7 | EEPROM malfunction | Contact service people |
| 4 | E8 | Indoor DC fan motor speed out of control | Contact service people |
| 5 | Ed | Outdodor Temp.sensor malfunction | Turn off the unit, clean the air filter, then restart the unit. If this operation does not work, please contact service people. |
| 6 | P0 | Evaporator low temperature protection under COOL and DRY mode. | Turn off the unit, clean the air filter, then restart the unit. If this operation does not work, please contact service people. |
| 7 | P1 | Anti-cold air or defrosting under heat mode | When the temperature is warm enough, the function stops automatically./The unit will aut restart after finishing the defrosting and the temperature of indoor Heat Exchanger raises. |
| 8 | P8 | Current overload protection | Contact service people |
| 9 | Ed | Outdoor protection | Turn off the unit, clean the air filter, then restart the unit. If this operation does not work, please contact service people. |
| The displayed error code differs from appliance to appliance. The actual display of the indoor unit shall prevail. | | | |

$\square P$ $\square dF$ $\square F$ show on the LCD of the indoor unit when the unit is in the normal operation. The three icons imply the three function respectively.

The icon $\square P$ implies the remote control function.

The icon $\square dF$ implies the defrosting function.

The icon $\square F$ implies the forced cooling function.

CAUTION:

- If the supply cord of this appliance is damaged, replacement work shall be performed by authorized personnel only.
- For the unit adopts PTC, the PTC heating components are fixed in the middle of bottom of the cabinet. Do not attempt to remove or repair these components by yourself, it may cause a fire or other danger.